



LifeCuffs<sup>TM</sup>

To Serve and Protect!<sup>TM</sup>

Inventor: Bene Ligatus

## Executive Summary

Cops need help. No cop wants a person in custody to have a medical emergency on their watch, but if a medical emergency occurs, all cops want to know about it right away so that they can call an ambulance so that the life of the person having the medical emergency can be saved. However, determining when a medical emergency is taking place can be a tough call for a street cop to make.

LifeCuffs™ are the solution! LifeCuffs™ allow the medical condition of a person in custody to be continuously monitored as soon as the cuffs go on. If the person in custody is experiencing a medical emergency, LifeCuffs™ instantly recognizes it, sounds an alarm, and calls 911 to send an ambulance to the location. LifeCuffs™ can't prevent a medical emergency from happening, but by using LifeCuffs™, police departments can honestly say their officers did everything they could -recognize when a medical emergency was happening as quickly as possible and save the life of the person in custody that was experiencing a medical emergency. Additionally, LifeCuffs™ frees arresting officers from having to make the often dangerous and frequently error-prone determination of whether an arrestee is experiencing an actual medical emergency – and hopefully saves lives by getting medical care on the scene as soon as possible.

LifeCuffs™ – To Serve And Protect!™

## Background

Our police have a hard job. We entrust them to uphold our laws and keep us all safe. As part of that job, the police are empowered to arrest those suspected of a crime. Often, when these arrests are made, the situation may be very dynamic and the conditions may be less than optimal, for example, arrests may be made at night, during a rain or snow storm, after a foot chase or physical confrontation, or the arrestee may be resisting arrest. Additionally, the medical condition of the arrestee is typically unknown to the arresting officer. However, the arrestee may be under the influence, have a pre-existing medical condition, or suffer from stress sufficient to medically impact them due to the arrest.

Further, the medical condition of the arrestee may change very rapidly at any point during the arrest or when the arrestee is in custody. However, although police officer training may include rudimentary medical training, they are not EMTs – and they are not doctors, much less doctors operating in a hospital situation with the advantages of all the latest health monitoring devices. Thus, despite their vigilance, our police officers may not immediately recognize when an arrestee is experiencing a medical emergency. Their job is also complicated because a significant number of arrestees may claim to have a medical emergency when they do not – whether their claim is intentionally false or merely a misinterpretation of the stress accompanying an arrest. On the other hand, some arrestees may be experiencing a medical emergency, but not inform the officer – either because they are physically unable to do so or because the arrestee is not themselves aware that they are experiencing a medical emergency.

Our police need to know when a person in custody is truly experiencing a medical emergency so that professional medical care can be summoned.

## LifeCuffs™ – To Protect And Serve!™

Fortunately, LifeCuffs™ are the solution! LifeCuffs™ allow the medical condition of a person in custody to be continuously monitored as soon as the cuffs go on. If the person in custody is experiencing a medical emergency, LifeCuffs™ instantly recognizes it, sounds an alarm, and calls 911 to send an ambulance to the location. LifeCuffs™ can't prevent a medical emergency from happening, but by using LifeCuffs™, police departments can honestly say their officers did everything they could to recognize when a medical emergency was happening and save the life of the person in custody that was experiencing a medical emergency. Additionally, LifeCuffs™ frees arresting officers from having to make the often dangerous and frequently error-prone determination of whether an arrestee is experiencing an actual medical emergency – and hopefully saves lives by getting medical care on the scene as soon as possible.

To use a simple analogy, LifeCuffs™ are like standard handcuffs with a built-in Fitbit<sup>1</sup> that monitors the arrestee's heartrate and blood oxygen. If either of them gets too high or too low, LifeCuffs™ sounds an alarm and calls 911 for an ambulance. LifeCuffs™ thus provides the absolute fastest recognition of when a medical emergency is occurring and places the 911 call for aid faster than any human police officer could.

The figure below shows a standard handcuffs with a polymer overmold<sup>2</sup>, which are available everywhere:

---

<sup>1</sup> [https://store.google.com/magazine/fitbit\\_technology?hl=en-US](https://store.google.com/magazine/fitbit_technology?hl=en-US)

<sup>2</sup> <https://www.handcuffwarehouse.com/asp-ultra-plus-handcuffs-with-keyless-double-lock-56060/>



LifeCuffs™ have a sensor suite positioned between the ribs of the polymer overmold to measure heartrate and blood oxygen level as shown below:

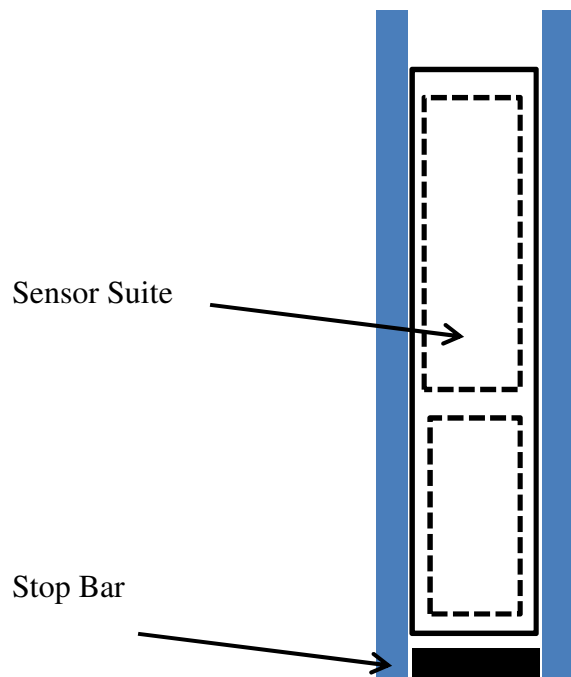

Here is a picture showing the changes to the standard polymer overmold to accommodate the LifeCuffs™

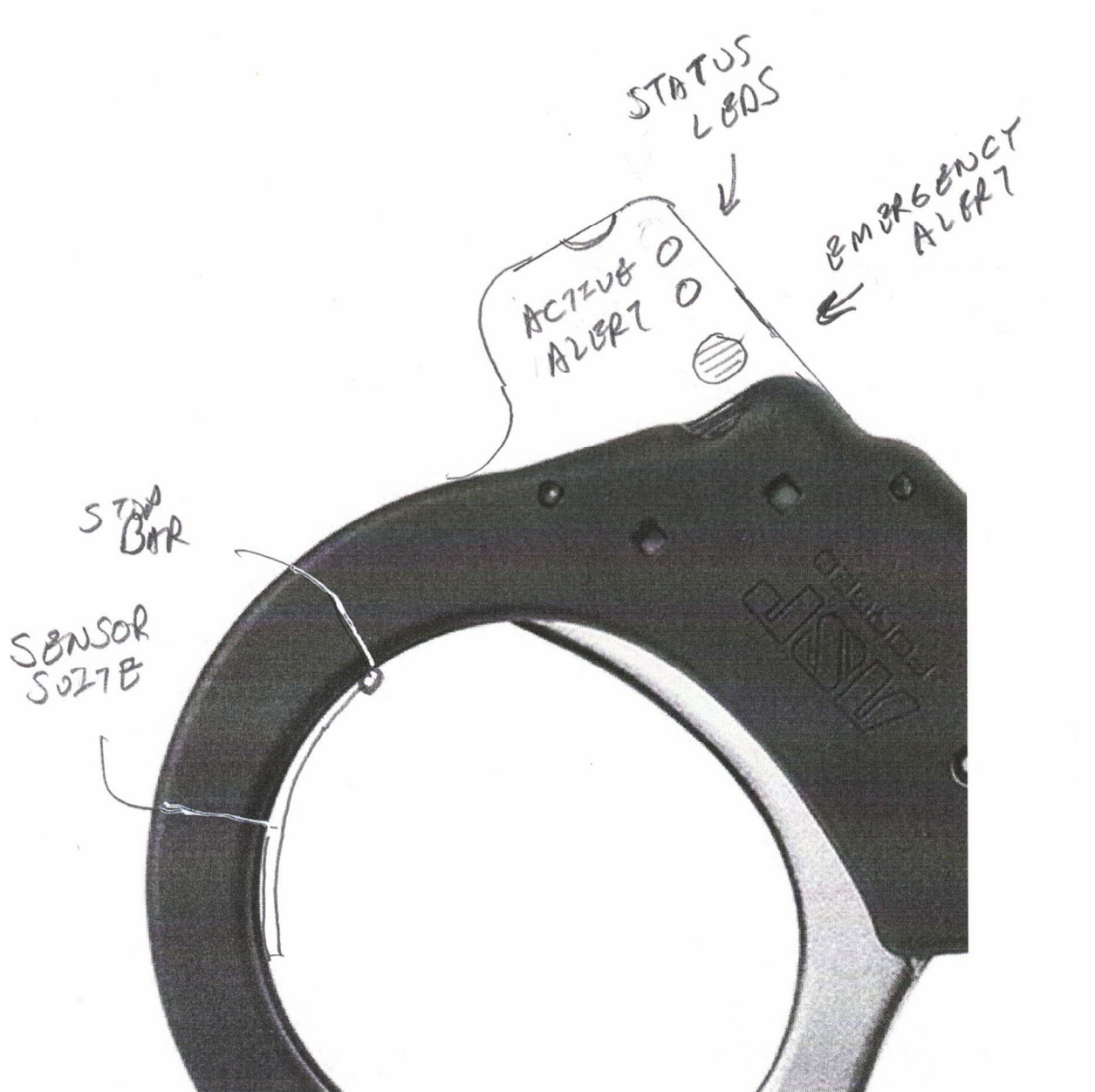

To set up the LifeCuffs™, each LifeCuffs™ may be paired using Bluetooth to either an officer's cell phone or a charging pack that includes a cellular connection.

Once the LifeCuffs™ are placed on an arrestee, the active LED indicates that they are active – and if a medical emergency occurs, the alert LED lights up and an alert sound is played. The LifeCuffs™ then send an alert signal to the officer's cell phone where the LifeCuffs™ App is installed. This causes the App to call 911 and report the emergency, including the current GPS location. An ambulance may then be immediately dispatched to that location.

**LifeCuffs™ - Save Lives!**

## Upcoming LifeCuffs™ Improvements

### Blood Pressure Monitoring

In practice, although the Fitbit currently allows the measurement of heartrate and blood oxygen the Fitbit currently lacks the sensor to determine blood pressure. However, a blood pressure sensor is currently available in the Samsung Galaxy Watch 7<sup>3</sup> We are in contact with their supplier and will be adding the blood pressure sensor to our sensor suite. We can then alert if blood pressure is too high or too low.

### Data Lockbox

We will offer a central data warehouse that preserves all medical and alerting data, including timestamps of when an alert was detected and when a 911 call was initiated for a monthly subscription. This data may be used by police departments to later establish the timeliness of the police response.

### Stress Monitoring

Heart rate variability (HRV) is the physiological phenomenon of variation in the time interval between heartbeats. It is measured by the variation in the beat-to-beat interval. In a nutshell, the interaction of the sympathetic and the parasympathetic nervous system (PSNS), which responds to stress, influences the variation of heart rate from one beat to the next. For example, in a non-stressed person, heart rate may vary more due to factors such as breathing. Conversely, it has been determined that a person experiencing stress has a lower HRV than a

---

<sup>3</sup> <https://www.samsung.com/us/watches/galaxy-watch7/buy/galaxy-watch7-40mm-cream-wifi-bluetooth-sm-l300nzeaxaa/>

relaxed person. That is, for stressed people, their heart beats more uniformly – too uniformly!

An accessible introduction to understanding HRV is available through Wikipedia.<sup>4</sup> The use of HRV as a measure of physiological stress is well established and accepted.<sup>5 6 7 8 9</sup>

Because a very high stress event is often a precursor to a medical event, once LifeCuffs™ measures the heartrate, it will also calculate the HRV and then alert if the HRV is too high.

---

<sup>4</sup> [https://en.wikipedia.org/wiki/Heart\\_rate\\_variability](https://en.wikipedia.org/wiki/Heart_rate_variability)

<sup>5</sup> <https://bmcpyschology.biomedcentral.com/articles/10.1186/s40359-021-00551-4#>

<sup>6</sup> <https://my.clevelandclinic.org/health/symptoms/21773-heart-rate-variability-hrv>

<sup>7</sup> <https://www.wellandgood.com/anxiety-heart-rate-variability/>

<sup>8</sup> <https://therapyinanutshell.com/measure-anxiety-in-your-nervous-system-with-heart-rate-variability-vagal-tone/>

<sup>9</sup> <https://www.health.harvard.edu/blog/heart-rate-variability-new-way-track-well-2017112212789>

## Other Patents

The CEO passed on your recommendation to search the PTO's website, so I did. I made a list of the patents that I found below. The CEO says that all of these patents look pretty close to what we came up with. However, the CEO says that you are the best patent attorney around and that you will be able to find a way to get us our patent without infringing on these other patents.

Patents:

US 20120298119 A1

US 20120118027 A1

US 10190340 B2